

LH534700

CMOS 4M (512K × 8) Mask-Programmable ROM

FEATURES

- 524,288 words × 8 bit organization
- Access time: 100 ns (MAX.)
- Power consumption:
 - Operating: 412.5 mW (MAX.)
 - Standby: 550 μW (MAX.)
- Static operation
- TTL compatible I/O
- Three-state outputs
- Single +5 V power supply
- Mask-programmable control pin:
 - Pin 1 = $OE_1/\overline{OE}_1/DC$
 - Pin 24 = OE/\overline{OE}
- Packages:
 - 32-pin, 600-mil DIP
 - 32-pin, 525-mil SOP

DESCRIPTION

The LH534700 is a 4M-bit mask-programmable ROM organized as 524,288 × 8 bits. It is fabricated using silicon-gate CMOS process technology.

PIN CONNECTIONS

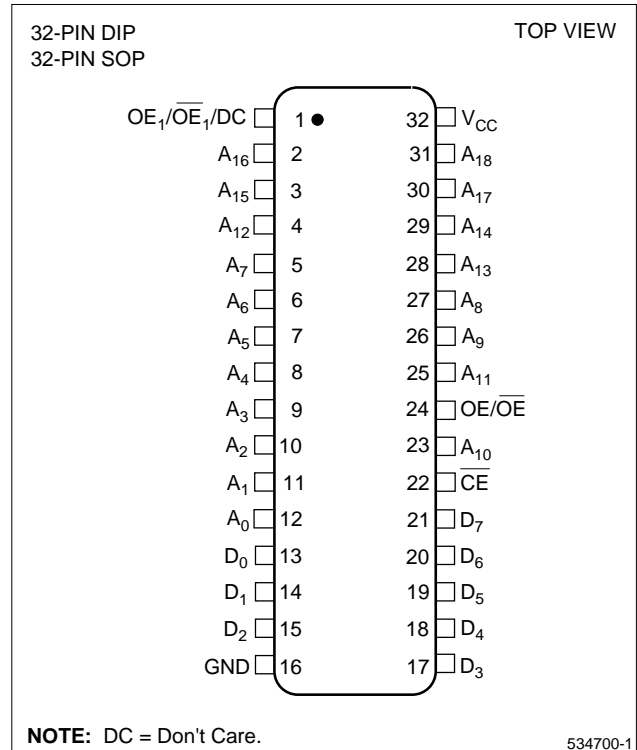
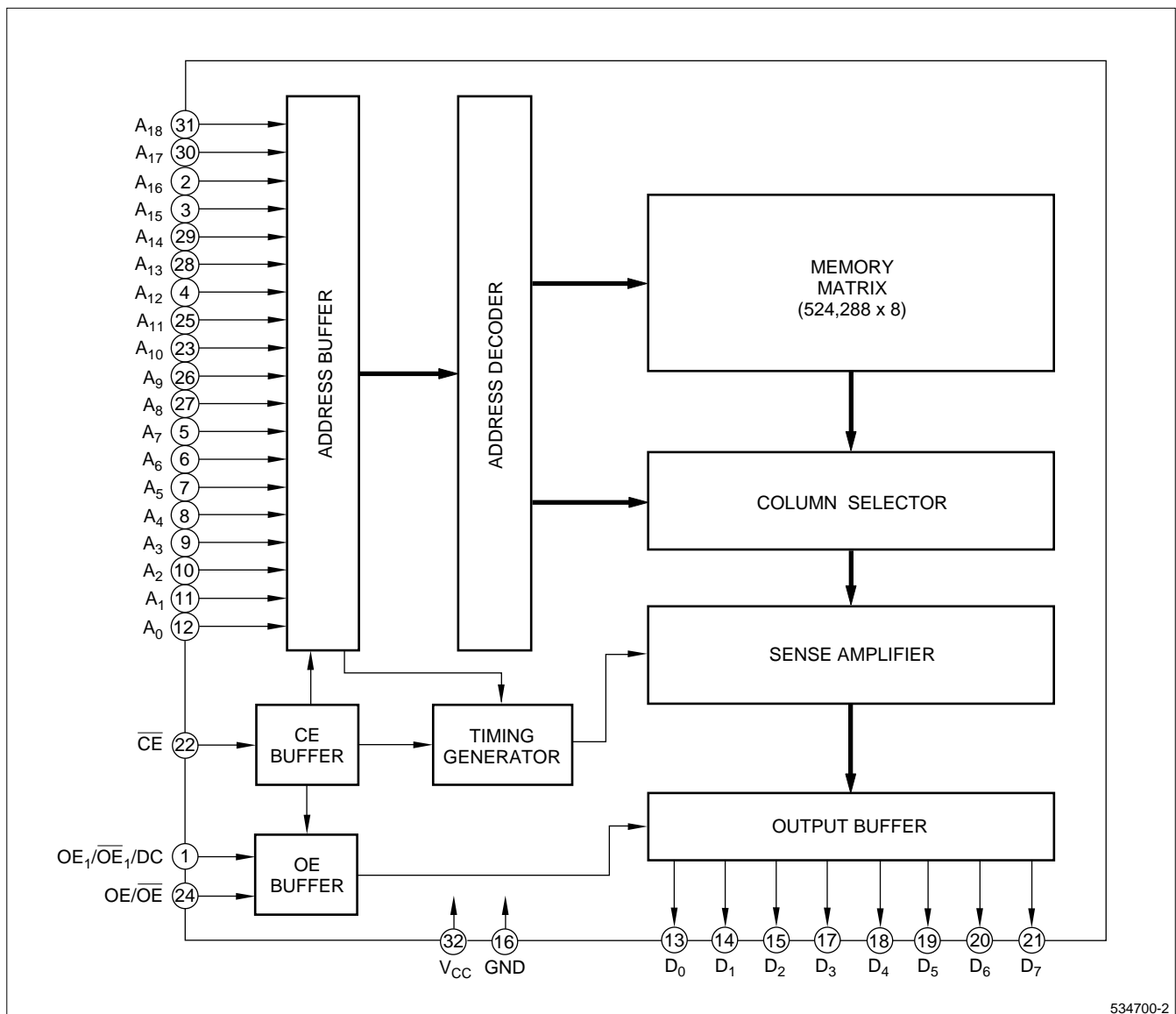

Figure 1. Pin Connections for DIP and SOP Packages



534700-2

Figure 2. LH534700 Block Diagram

PIN DESCRIPTION

SIGNAL	PIN NAME	NOTE
A ₀ – A ₁₈	Address input	
D ₀ – D ₇	Data output	
\overline{CE}	Chip enable input	
OE/ \overline{OE}	Output enable input	1

SIGNAL	PIN NAME	NOTE
OE ₁ / \overline{OE} ₁ /DC	Output enable input	1, 2
V _{CC}	Power supply (+5 V)	
GND	Ground	

NOTES:

- Active levels of OE/ \overline{OE} and OE₁/ \overline{OE} ₁/DC are mask-programmable. When DC is selected out of OE₁/ \overline{OE} ₁/DC, it is fixed to an active level. It is recommended to apply either 'High' or 'Low' to the DC pin.
- DC = Don't care.

TRUTH TABLE

\overline{CE}	OE_1/\overline{OE}_1	OE/\overline{OE}	DATA OUTPUT	SUPPLY CURRENT
H	X	X	High-Z	Standby (I_{SB})
L	L/H	X		Operating (I_{CC})
L	X	L/H		
L	H/L	H/L	Output	

NOTE:

X = H or L

ABSOLUTE MAXIMUM RATINGS

PARAMETER	SYMBOL	RATING	UNIT
Supply voltage	V_{CC}	-0.3 to +7.0	V
Input voltage	V_{IN}	-0.3 to $V_{CC} + 0.3$	V
Output voltage	V_{OUT}	-0.3 to $V_{CC} + 0.3$	V
Operating temperature	T_{opr}	0 to +70	°C
Storage temperature	T_{stg}	-65 to +150	°C

RECOMMENDED OPERATING CONDITIONS ($T_A = 0^\circ\text{C}$ to $+70^\circ\text{C}$)

PARAMETER	SYMBOL	MIN.	TYP.	MAX.	UNIT
Supply voltage	V_{CC}	4.5	5.0	5.5	V

DC CHARACTERISTICS ($V_{CC} = 5\text{ V} \pm 10\%$, $T_A = 0^\circ\text{C}$ to $+70^\circ\text{C}$)

PARAMETER	SYMBOL	CONDITIONS	MIN.	TYP.	MAX.	UNIT	NOTE
Input 'Low' voltage	V_{IL}		-0.3		0.8	V	
Input 'High' voltage	V_{IH}		2.2		$V_{CC} + 0.3$	V	
Output 'Low' voltage	V_{OL}	$I_{OL} = 2.0\text{ mA}$			0.4	V	
Output 'High' voltage	V_{OH}	$I_{OH} = -400\ \mu\text{A}$	2.4			V	
Input leakage current	$ I_{LI} $	$V_{IN} = 0\text{ V to }V_{CC}$			10	μA	
Output leakage current	$ I_{LO} $	$V_{OUT} = 0\text{ V to }V_{CC}$			10	μA	1
Operating current	I_{CC1}	$t_{RC} = 100\text{ ns}$			75	mA	2
	I_{CC2}	$t_{RC} = 1\ \mu\text{s}$			65		
	I_{CC3}	$t_{RC} = 100\text{ ns}$			70	mA	3
	I_{CC4}	$t_{RC} = 1\ \mu\text{s}$			60		
Standby current	I_{SB1}	$\overline{CE} = V_{IH}$			3	mA	
	I_{SB2}	$\overline{CE} = V_{CC} - 0.2\text{ V}$			100	μA	
Input capacitance	C_{IN}	$f = 1\text{ MHz}$			10	pF	
Output capacitance	C_{OUT}	$T_A = 25^\circ\text{C}$			10	pF	

NOTES:

- $\overline{CE}/\overline{OE}/\overline{OE}_1 = V_{IH}$, $OE/\overline{OE}_1 = V_{IL}$
- $V_{IN} = V_{IH}$ or V_{IL} , $\overline{CE} = V_{IL}$, outputs open
- $V_{IN} = (V_{CC} - 0.2\text{ V})$ or 0.2 V , $\overline{CE} = 0.2\text{ V}$, outputs open

AC CHARACTERISTICS ($V_{CC} = 5\text{ V} \pm 10\%$, $T_A = 0^\circ\text{C}$ to $+70^\circ\text{C}$)

PARAMETER	SYMBOL	MIN.	MAX.	UNIT	NOTE
Read cycle time	t_{RC}	100		ns	
Address access time	t_{AA}		100	ns	
Chip enable access time	t_{ACE}		100	ns	
Output enable delay time	t_{OE}		50	ns	
Output hold time	t_{OH}	0		ns	
CE to output in High-Z	t_{CHZ}		50	ns	1
OE to output in High-Z	t_{OHZ}		50	ns	

NOTE:

1. This is the time required for the outputs to become high-impedance.

AC TEST CONDITIONS

PARAMETER	RATING
Input voltage amplitude	0.4 V to 2.6 V
Input rise/fall time	10 ns
Input/output reference level	1.5 V
Output load condition	1TTL + 100 pF

CAUTION

To stabilize the power supply, it is recommended that a high-frequency bypass capacitor be connected between the V_{CC} pin and the GND pin.

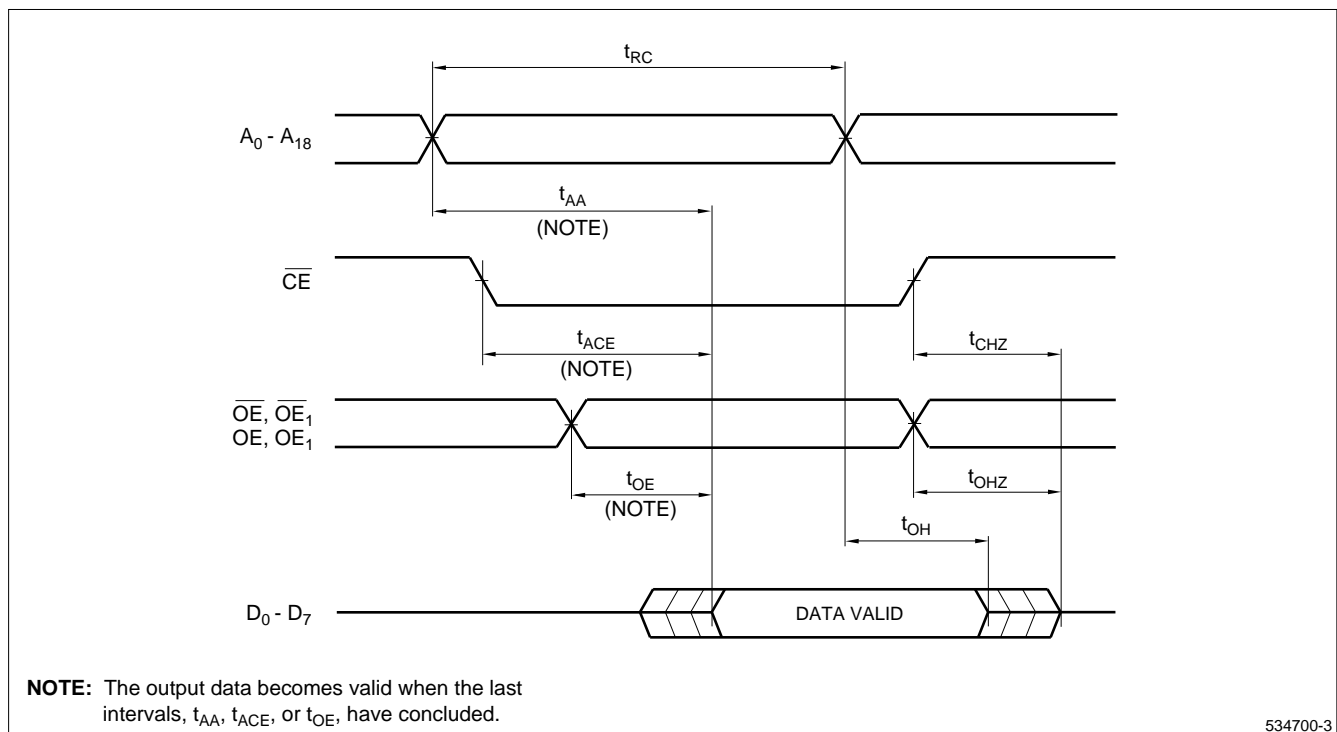
**Figure 3. Timing Diagram**

PACKAGE DIAGRAMS

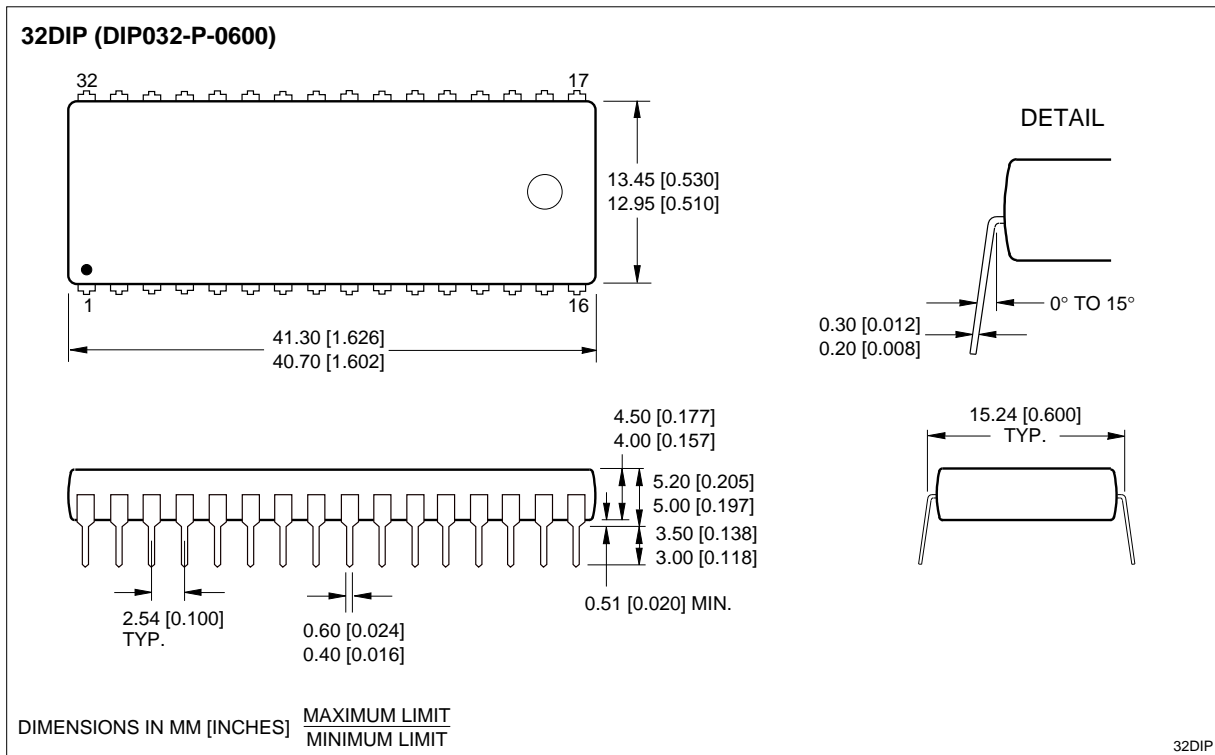

32-pin, 600-mil DIP

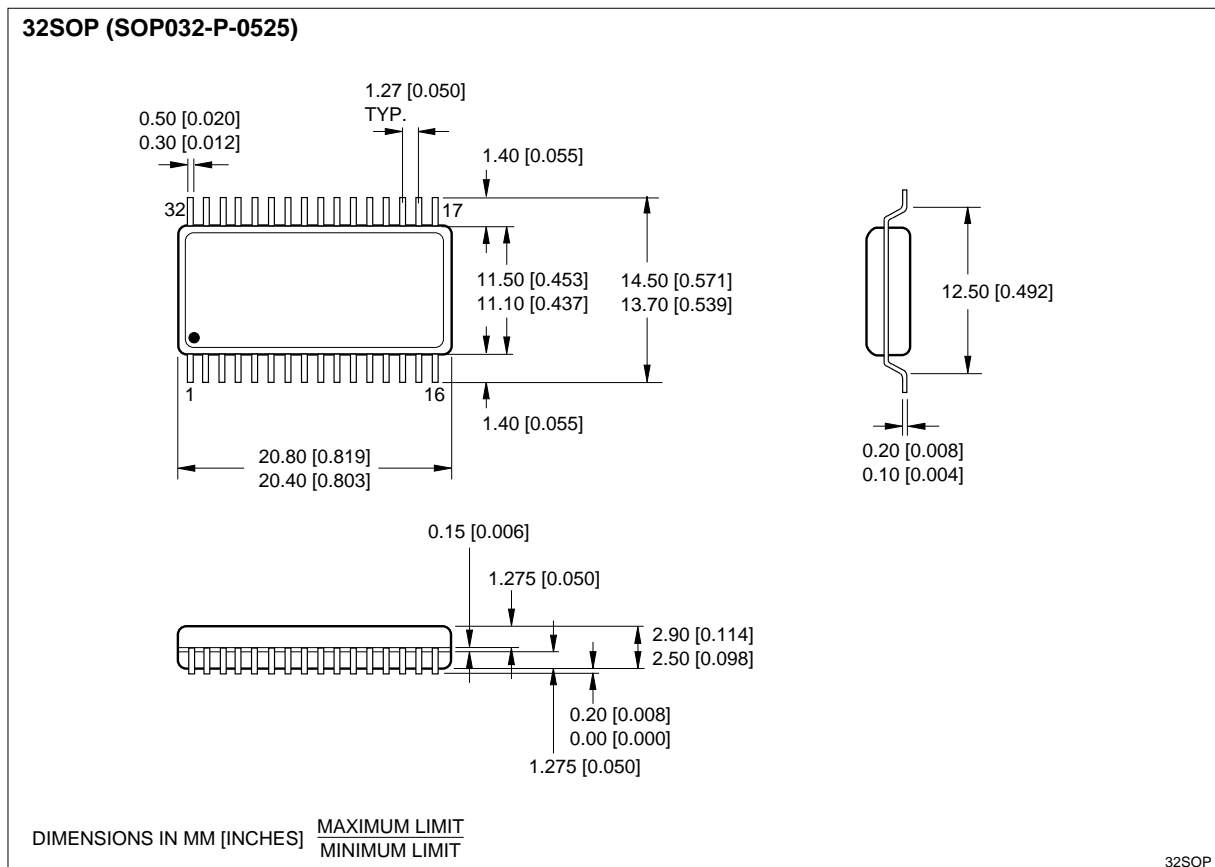

32-pin, 525-mil SOP

ORDERING INFORMATION

